

Round flange bearing units

FC



- **Waterproof housing**
- **Shaft shoulders locking**
High axial load capacity.
- **PA FV polyamide housing**
High mechanical and heat resistance.
Proof to dust, humidity, washouts, steam, average aggressive chemical agents
- **PP FV polypropylene housing**
Proof to highly aggressive chemical agents.
Inferior loading ability.

Material

PA FV polyamide housing

- Housing in reinforced polyamide PA FV resin (black)
- Seal and O-Ring in NBR rubber (black)
- Ball type nickel plated brass greasing nipple
- Reinforcing bushings on mounting holes and washers in stainless steel AISI 304.

PP FV polypropylene housing

- Housing in reinforced polypropylene PP FV resin (black)
- Seal and O-Ring in NBR rubber (black).
On request supplied in Viton rubber (brown).
Viton material offers high resistance to chemical agents.
- Ball type stainless steel AISI 316 greasing nipple
- Reinforcing bushings on mounting holes and washers in stainless steel AISI 316.

Continuous operating temperature

n air : - 20 to + 60°C.

Maximum allowed misalignment : 2°.

Bearing

- Series 1200 self aligning ball bearing
- Chrome alloy steel
- Supplied without grease
- To be prelubricated with lithium / calcium grease during first installation.

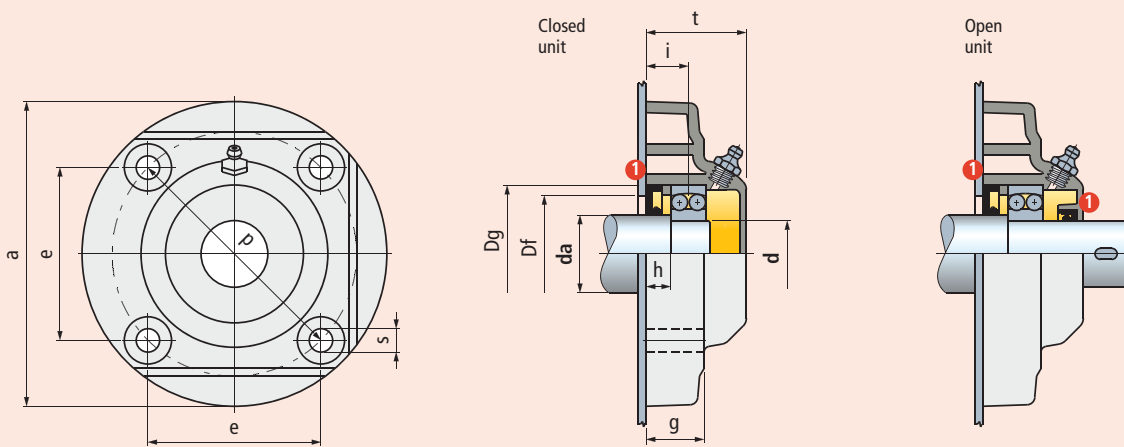

1 Seal.